

This price list is an indication of our current stock but you should not be under the impression that you require every part listed to build your car. Many of the items can be used from the donor car, obtained second-hand, fabricated or sourced from elsewhere - so it is quite possible to build a stunning car economically. On the other hand, for the owner who does not have the time or inclination to search for alternatives we can provide every part needed for the build. Every item we supply is right for the job so you can be sure that the car will go together with the minimum of effort when you use our parts.

## Body/Chassis Options

|   |   |
|---|---|
| <b>Hawk 2.6 &amp; 1.8</b>   | <b>£6400.00</b>   |
| Body/chassis kit. Chassis will accept MGB engine & gearbox. The same chassis will also accept Triumph 2.5 six cylinder engine & gearbox. Mountings for BMW six cylinder engine to special order   |   |
| <b>Hawk 289</b>   | <b>£6650.00</b>   |
| Body/chassis kit. Bracketed for either Rover V8 or Ford 302 V8  |   |
| <b>Hawk 289 FIA Body/Chassis kit</b>  | <b>£6900.00</b>   |
| <b>Hawk Sebring 289</b>   | <b>£6800.00</b>   |
| <b>Hawk Le Mans</b>   | <b>£7250.00</b>   |
| Body/chassis/hardtop kit. Bracketed for either Rover V8 or Ford 302 V8  |   |
| <b>All models</b>   | Standard body colour grey. Internal panels are black - White to special order. extra <b>£400.00</b> |
| <b>IVA Seat Belt Mounting Kit</b> With stainless loops  | <b>£268.00</b>  |
| <b>Note All body styles are interchangeable with chassis</b>  |   |
| <b>IRS</b>  | <b>£680.00</b>  |
| All kits can be supplied to accept IRS. This utilises Jaguar XJ differential, driveshafts, brakes, calipers, lower links & uprights. Price includes the modifications to the customers drive shafts, lower links and hub carriers (however we do not recommend this option with 2.6/1.8). |   |
| <b>Hood Scoop (2 types. Fitted)</b>   | <b>£140.00</b>  |
| Fitted as standard on FIA or Le Mans & 39PH   |   |

All kits include a special pedal box (to accept bias balance bar).

## MG Donor Parts Package - We have a recommended supplier of donor parts. Please ask.

## Hubs & Wheels

|  |                                |
|--|--------------------------------|
| <b>MGB Splined Hubs Front</b>  | each <b>£84.50</b>             |
| <b>MGB Splined Hubs Rear</b>   | each <b>£84.50</b>             |
| <b>MGB Converter Splined Hubs</b>  | <b>£84.50</b>                  |
| Can be used to narrow track for rear of 1.8 or 2.6 models when using tube-type wire wheel axle                           |                                |
| <b>Special Splined Hubs</b>  | pair <b>£380.00</b>            |
| To fit Jaguar rear uprights. These allow genuine wheels, or rear wheels to match the front, to be fitted on IRS versions |                                |
| <b>Wire Wheels - Painted</b> 289 original pattern.   | each <b>£198.00</b>            |
| <b>Wire Wheels - Chrome</b> 289 original pattern.  | each <b>£272.00</b>            |
| <b>289 FIA wheels</b> 6.5 and 8.5 x 15, peg drive (Splined drive type also available, <b>£480</b> per set extra.)        | Set of 4 <b>£2000.00</b>       |
| <b>Wire Wheels for Hawk 1.8 &amp; 2.6 - Painted - Chrome</b>   | <b>165.00</b><br><b>250.00</b> |
| <b>Spinners</b> Two ear.   | per set from <b>£140.00</b>    |
| <b>SVA Octagonal Spinners</b> Polished chrome with Hawk emblem   | each <b>£54.00</b>             |
| <b>Special Spanner</b> To fit above  | <b>£28.00</b>                  |
| <b>Special Hammer</b>  | <b>£34.00</b>                  |
| <b>Tri-Wing FIA Spinners</b> for Alloys  | Set of 4 <b>£595.00</b>        |

## Suspension Parts

|   |                         |
|---|-------------------------|
| <b>NEW - Adjustable Front Suspension System*</b>  | <b>£980.00</b>          |
| Fully adjustable. Powder coated. Accepts MGB hubs, stub axles, brakes and pivot rods etc. (not included).   |                         |
| <b>Anti-tramp Bars &amp; Panhard Rod (MGB rear axle) Std Kit</b>  | <b>£285.00</b>          |
| Fully adjustable, powder coated, fitted with Nylatron bushes and supplied with plated brackets & all necessary nuts and bolts for use with original MGB lever arm shock absorbers (lower brackets required on exchange) |                         |
| <b>Panhard Rod</b> Kit available separately   | <b>£170.00</b>          |
| <b>Special Leaf Springs</b> To suit MGB axle cars   | each <b>£88.00</b>      |
| <b>Aluminium Packer Kit</b> Specially for above   | per set <b>£38.00</b>   |
| <b>Special Springs</b> For Jaguar IRS conversion.   | Set of 4 <b>£120.00</b> |

The excellent alternative to using standard MGB suspension on the Hawk 289s. It is also a very popular and beneficial conversion for the MGB. (Shown here fitted to an MGB crossmember).

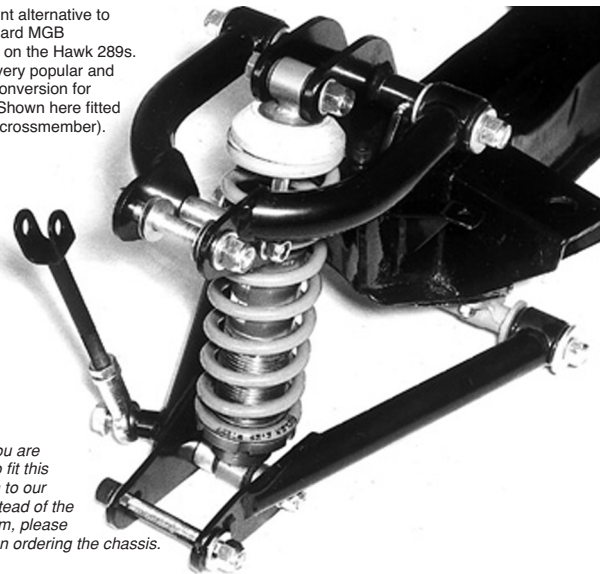

**\*Note.** If you are intending to fit this suspension to our chassis instead of the MGB system, please advise when ordering the chassis.

|  |   |                         |
|--|---|-------------------------|
| <b>Special Spring Shockers</b>   | Adjustable rate, adjustable spring seats. For Jaguar IRS.   | Set of 4 <b>£480.00</b> |
| <b>Front Anti-Roll Bar</b> 3/4" or 5/8" front anti-roll bar                        |   | <b>£88.00</b>           |
| <b>Windscreen</b>  |   |                         |
| <b>Windscreen</b> Clear (SVA compatible - £20 extra)                               |   | <b>£545.00</b>          |
| <b>Windscreen</b> Escutcheons  |   | pair <b>£22.00</b>      |
| <b>Interior Mirror</b> Chrome - SVA compatible                                     |   | <b>£40.00</b>           |
| <b>Mirror Edge Protector</b> Fits above  |   | <b>£7.50</b>            |
| <b>Windwings</b> Toughened glass   |   | pair <b>£89.00</b>      |
| <b>Sunvisors</b>   |   | pair <b>£89.00</b>      |
| <b>Special SVA Side Mirrors</b> To fit on windscreen frame                         |   | each <b>£52.00</b>      |
| <b>Special SVA Screen Pillar Mountings</b> - saves drilling pillars                |   | pair <b>£21.00</b>      |
| <b>Brightwork</b>  |   |                         |
| <b>Roll-over bar</b> Single with forward strut, black                              |   | <b>£350.00</b>          |
| <b>289 Front Nudge Bars</b> Finished in high quality chrome with mounting kit      |   | <b>£174.00</b>          |
| <b>Rear Nudge Bars</b> As above  |   | <b>£174.00</b>          |
| <b>Overriders</b> Set of four  |   | <b>£320.00</b>          |
| <b>Handbrake Chrome</b>  | Original style. Exchange item requiring MGB handbrake lever | <b>£170.00</b>          |
| <b>Handbrake Chrome</b> Outright price   |   | <b>£195.00</b>          |
| <b>289 Radiator Grille</b> Original pattern. Made in aluminium                     |   | <b>£295.00</b>          |
| <b>1.8 &amp; 2.6 Rad. Grille</b> Original pattern. Made in aluminium               |   | <b>£295.00</b>          |
| <b>Ally Quick Lifts</b>  |   | <b>£220.00</b>          |
| <b>Side Vents</b> Made in aluminium to original specification                      |   | pair <b>£142.00</b>     |
| <b>Bonnet Stay</b> Plated. In original style                                       |   | <b>£62.00</b>           |
| <b>Door Catches</b> Fitted free of charge if ordered with kit                      |   | <b>£190.00</b>          |
| <b>Steering Wheel</b> A special 289 wheel with billet boss - fits early MGB column |   | <b>£300.00</b>          |
| <b>Steering Wheel</b> A special 2.6 wheel with boss - fits early MGB column        |   | <b>£300.00</b>          |
| <b>Bonnet and Boot Handle Set</b>  | With latches, catch plates, Glove Box Lock etc.             | set <b>£152.00</b>      |

## Brakes - see also Clutch & Brakes

**Brakes** 4 pot ventilated brake conversion - will fit other MGB-based kits £695.00

## Interior Trim

**Full Trim Kit** £915.00  
Gear lever gaiter, Handbrake gaiter, Door panels and A panels in Black Leather plus carpet set.

**Leather Seats** Top quality, original design on steel frame pair £1170.00

**Seat shells** High quality, strong GRP moulding each £120.00

**FIA type Competition Seats** Trimmed in vinyl each £300.00

## Weather Equipment

**Hood** Mohair (Black) £625.00

**Hood** (Black) Including sticks and screen bows & over centre catches £840.00

**Tonneau Cover** Mohair (Black) £290.00

**Tonneau Cover** To fit roll bar - Mohair (Black) £348.00

**Sidescreen frame kit** Metal frames - needs final fitting set £205.00

**Sidescreen Perspex** Prepared but need final fitting set £105.00

**Hardtop** Hardtop moulding & rear window £660.00

**Hardtop Le Mans** Le Mans hardtop and rear window £920.00

**Over-centre Catches** For Le Mans & Standard hardtop or hood pair £48.00

**Metal Corners** For fitting above to hardtops pair £42.00

**Hood Bows** £79.00

**Hood Sticks** £90.00

## Electrical

**Wiring Loom** £545.00  
A custom loom complete with relays, fuse box, switches and immobiliser. Specify engine.

**Headlamps** 7" with sidelights incorporated pair £120.00

**Headlamp Rims** For above headlamps pair £38.00

**Rear Lights** SVA compliant, 2 red, 2 amber, 2 reflectors set £74.00

**Side Repeater Lights** SVA compliant each £22.00

**L542 Rear Lights** - original, when available pair £108.00

**L539 Front indicators**, clear or amber each £38.00

**Number Plate Light** Chrome £29.00

**Wiper Motor Kit** Complete with rack, gear pad & strap £198.00

**Wheel Box** For wiper system, with chrome plinths each £40.00

**Wiper Arm** Stainless adjustable each £13.60

**Wiper Blade** Stainless each £12.60

**Horns** Twin tone pair £26.00

**Battery Isolator Switch** £18.00

**Indicator/horn switch** Original style £150.00

**Adaptor** For above to fit MGB column £22.00

**Alternator Bracket** £64.00

**Heater** £285.00

## Clutch & Brakes

**Clutch Line** Braided stainless steel for Ford, Rover or Triumph - specify £48.00

**Brake & Clutch Master Cylinders - (3 required)** each £59.00

**Reservoirs** For above each £24.00

**Reservoirs** With sensors for SVA brakes each £45.00

**Brake Balance Bar** With safety spacers £72.00

**Brake Pipe Kit** £142.00

Includes stainless, flexible hoses, unions, banjos, T-pieces, nuts, clips, brake light switch & enough high quality Cupro-nickel solid line & pipes from master cylinder to reservoirs

**Handbrake Cable** Specify axle type £46.00

## Fuel System

**Fuel Tank** Custom made to a high standard in stainless steel - 289, 1.8/2.6 £325.00

**Fuel Tank** Custom made to a high standard in stainless steel - FIA, Le Mans £365.00

**Filler Caps** 2" outside diameter tube base. Locking £58.00

**Filler Caps** Original non locking - Ace / Cobra £118.50

**Large Original Style Alloy Racing Cap & Flange** For FIA & Le Mans £220.00

**Fuel Line Kit** Stainless braided hose, with clips and unions for Ford 302 V8 £205.00

**Fuel Line Kit** As above for Ford 302 V8 with 801 Holley pump & Filter King £337.00

**Fuel Line Kit** As above for Rover V8 £202.00

**Fuel Line Kit** As above for Rover V8 with fuel pump & Filter King £285.00

**Fuel Line Kit** As above for Triumph Six (No pump) £175.00

## Exhaust

**Exhaust System** P.O.A.

Complete system includes rubber mounts, clamps & stainless steel box. For Triumph or MGB engine (retain cast manifold)

**Exhaust System** £995.00

Stainless steel 4-box system for Rover V8 includes all clamps & mounts specify IRS or live axle (requires special manifold)

**Exhaust System** Special tubular manifold for Rover £420.00

**Exhaust System** As above, but for Ford 302 V8 (requires special manifold) £995.00

**Exhaust System** Special tubular manifold for Ford 302 V8 £420.00

## Engine Cooling

**Radiator Mounts** £30.00

For MGB V8 radiator with Rover or Triumph engine or special radiator. Specify which.

**Header Tank** For radiator. Aluminium with mounting brackets £165.00

**Radiator Cooling Fans** Very powerful and effective each £118.00

**Quick Mounts** For above each £10.00

**Special Radiator** For Ford or Rover V8 - high capacity £425.00

## Prop Shafts

**Rover / MGB or Rover / Jag** £190.00

**Ford / Jag** £216.00

## Jaguar rear axles

P.O.A.

Fully refurbished, new discs, reconditioned brakes, new bearings, correct length, plated and powder coated

*Please note that we require a deposit of £500 with order for body/chassis kits (£750 for FIA, Le Mans & 39PH) with the balance payable 7 working days before collection. For other items full payment should be sent with order.*

All prices are correct at time of going to press. However, Hawk Cars Limited reserve the right to alter prices and specifications without prior notice.

Should you require any item not listed here, please do not hesitate to contact us because our stocks of other items are constantly changing. We can usually obtain any part you require. For any further information or advice please do not hesitate to ring us on 01892 750341 or Fax us on 01892750071

**Hawk Cars Limited, Oakdene, Riverhall Hill, Frant, East Sussex TN3 9EP.**

**Tel: (01892) 750341 / 750282 Fax: (01892) 750071 Email: gerry@hawkcars.co.uk**

www.hawkcars.co.uk

